

# Rack Panel Kit

## INSTALLATION INSTRUCTIONS

Model RPK 005 Single Rack Panel Kit  
 Model RPK 006 Dual Rack Panel Kit  
 For use with Williams Sound 1/2 rack products



### RPK 005 Single Rack Panel Kit

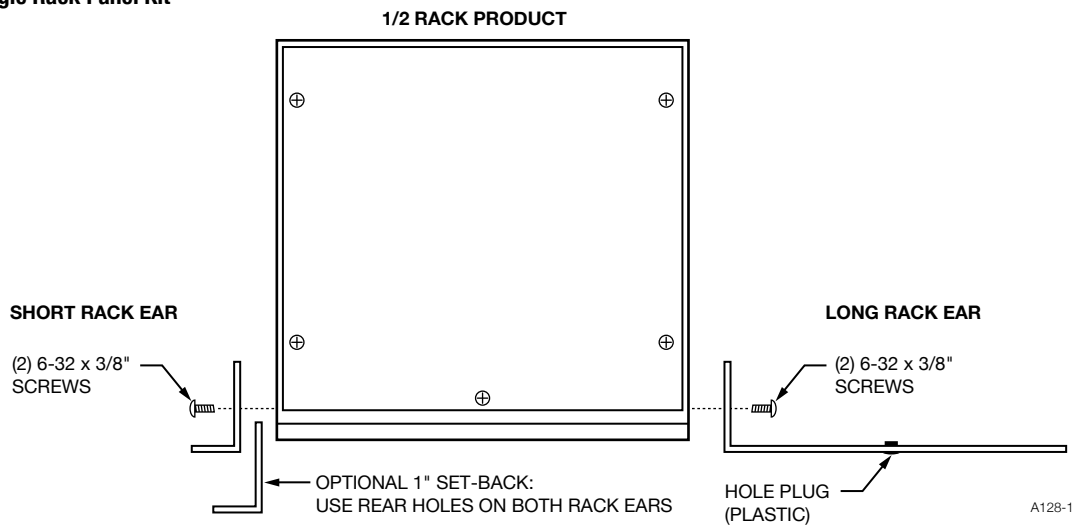

## RPK 005 Installation Steps

1. Attach the short and long rack ears as shown with four 6-32 x 3/8" machine screws. Use the front set of holes on the rack ears for a flush mount. Use the rear set of holes on the rack ears for a 1" recessed mount.
2. Attach the rack panel assembly to the rack with the machine screws and nylon washers provided.

**RPK 006 Dual Rack Panel Kit**

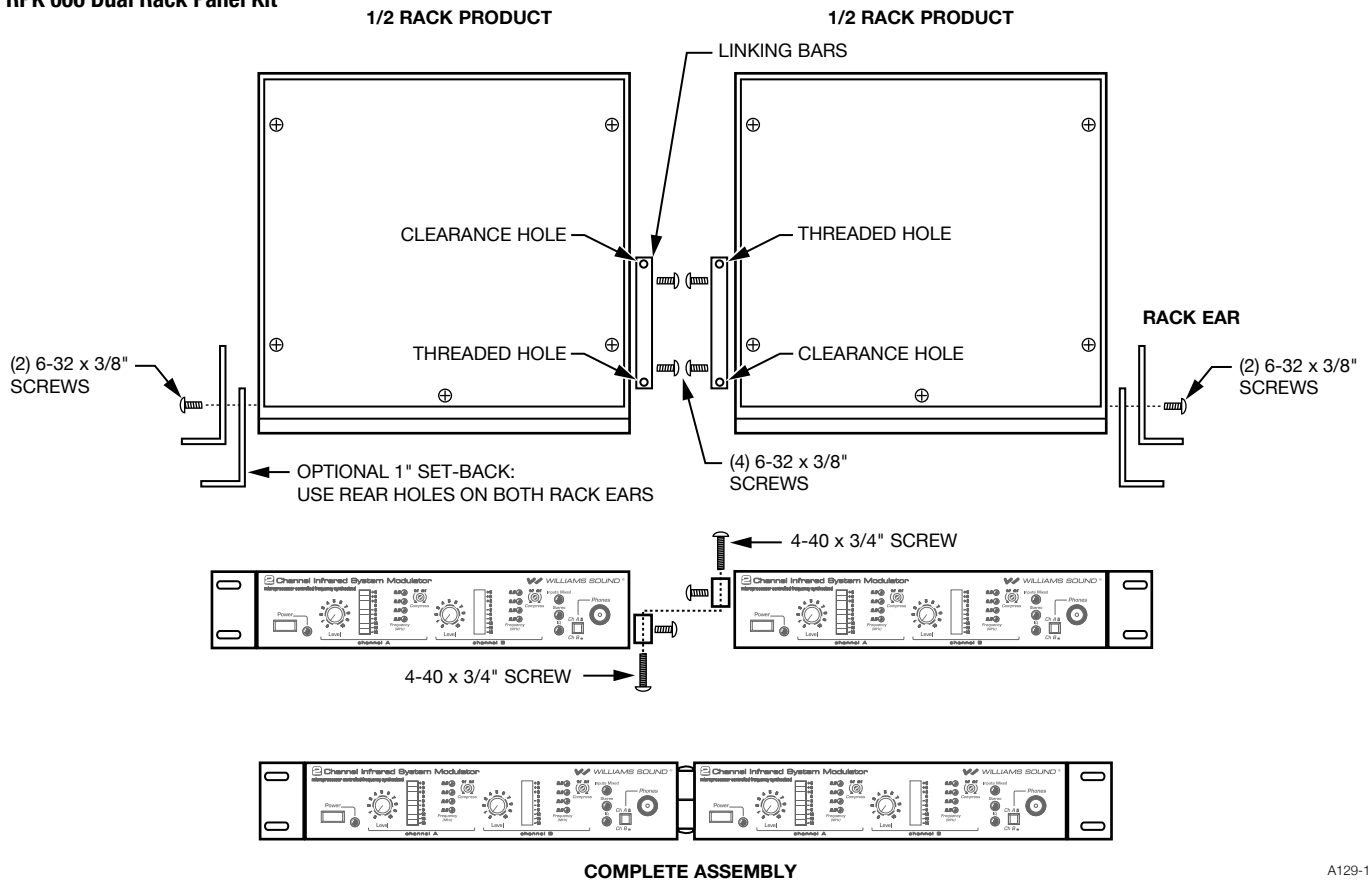

A129-1

## RPK 006 Installation Steps

1. Attach the short rack ears as shown with four 6-32 x 3/8" machine screws. Use the front set of holes on the rack ears for a flush mount. Use the rear set of holes on the rack ears for a 1" recessed mount.
2. Attach the linking bars to each 1/2 rack unit as shown with four 6-32 x 3/8" machine screws. Be sure to install the linking bars so the clearance hole in one bar is next to the threaded hole in the other.
3. Place the two 1/2 rack units together, so the linking bars overlap. Use two 4-40 x 3/4" machine screws to tie the linking bars together, as shown in the lower drawing.
4. Attach the rack panel assembly to the rack with the machine screws and nylon washers provided.

## Recycling Instructions



Help Williams Sound protect the environment! Please take the time to dispose of your equipment properly.

**Product Recycling for Customers in the European Union:**

Please do NOT dispose of your Williams Sound equipment in the household trash. Please take the equipment to a electronics recycling center; OR return the product to the factory for proper disposal.



10300 Valley View Rd • Eden Prairie, MN 55344  
 800-328-6190 / 952-943-2252 • FAX: 952-943-2174  
 www.williamssound.com