

PLA DL 210 NET, PLA DL 210 NET D

Digi-Loop™ Large Area DSP Dual Channel Loop Amplifiers



Digi-Loop is definitely state-of-the-art – the first of its kind to maximize modern amplifier technology. Its network-control capability provides seamless, remote system set-up, operation and monitoring via laptop or tablet. DSP audio processing offers flexible, powerful software control of mixing, equalization, compression, loop phase shift and more. Powerful Class D, pulse-width amplifiers maximize efficiency. The Digi-Loop's dual-amplifier design offers

flexibility, with the option of single 12A loop output for a perimeter loop, or dual 10A loop outputs for two loops or a loop array, or one loop/one loudspeaker. Priority input (70-100V) is also available for connection to a paging system (or distributed speaker system), ensuring announcements are heard by loop users. Use Digi-Loop with Williams Sound Digi-Wave products for crystal-clear wireless audio input.

FEATURES / BENEFITS

- DSP Audio Processing
- Digital AES/EBU Inputs
- Dante™ Input*
- Crestron control
- Wireless Control with Windows-based tablet or iPad (Apple iOS)
- LCD Screen with Metering
- Ethernet, RS-232, and USB control
- Mixing, Equalization, Compression, Phase, and Frequency-Shaping
- Power-save mode
- Master Gain Control
- High output current: 12/10 amps

- Active protection against short circuits
- XLR input configurable as microphone input or line-input, balanced or unbalanced
- Standard 2 RU, 19" rack enclosure
- Magnetic signal couples directly to devices equipped with telecoils (T-coils) such as hearing aids or cochlear implants
- Can be used with optional loop receivers
- Suitable for perimeter and low overspill phased array configuration
- Meets ADA / ADAAG guidelines

*Dante input available on Model PLA DL 210 NET D only

Digi-Loop DSP Dual Channel Loop Amplifiers

Rear Jacks - PLA DL 210 NET D

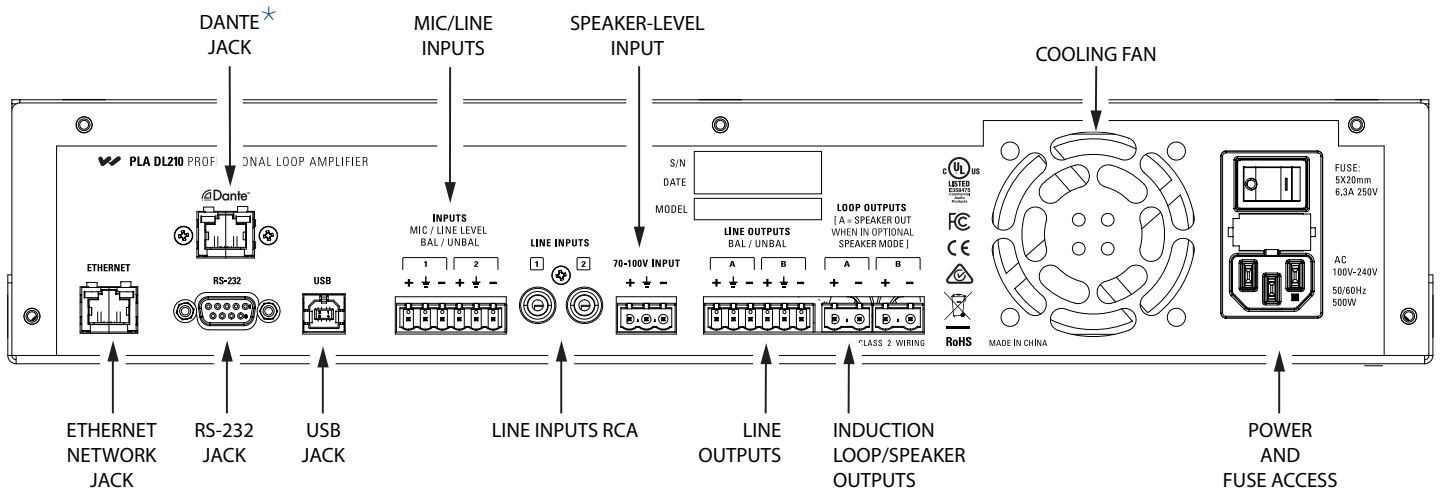

*The Dante jack is only available on model PLA DL 210 NET D. This jack is not present on the PLA DL 210 NET; the hole is covered by a blank metal plate on the interior of the chassis.

Dante Ethernet Jack LED Indication

(note: this differs from standard ethernet):

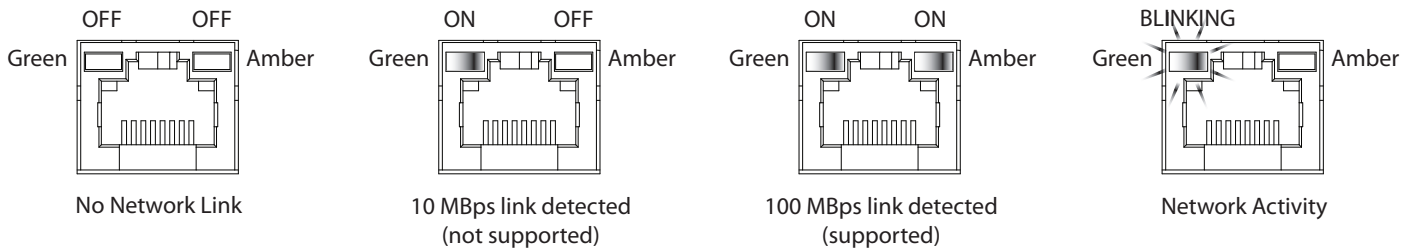

Digi-Loop DSP Dual Channel Loop Amplifiers

PLA DL 210 NET, PLA DL 210 NET D Specifications

Dimensions	2U Rackmount, 19" W x 3.5" H x 12" D. Chassis is 17" W.
Weight	14.3 lbs (6.5 kg)
Color	Case: Black, white and blue legends on front, white legends on back. LCD: Backlit Blue.
Fan Cooling	Variable Speed, Temperature Controlled
Power	100-240 VAC, 50/60 Hz, 500 Watt
Heat Output	Sleep state: 83 BTU Idle State: 112 BTU Driving two loops @9A each: 286 BTU
Digital Input	(1x XLR); AES or EBU; 44.1kHz/48kHz (1x RJ-45); Dante (Model PLA DL210NET-D only)
Analog Line Inputs	(1x RCA, L+R); -10dBV, 10k Ω input impedance
Mic/Line Inputs	(2x Phoenix Terminal Block); balanced or unbalanced. Input impedance: 1.5k Ω Mic, 10k Ω Line. Configurable/accepts Mic, Line +4dBu, Line +8dBu, or Line -10dBV.
70-100v Input	(1x Phoenix Terminal Block); speaker-level input, for distributed audio systems.
Line Outputs	(2x Phoenix Terminal Block); loop-through of Mic/Line inputs 1 & 2. +4dBu. Balanced or Unbalanced.
Loop Outputs	(2x Phoenix Terminal Block). One Loop, Output A or B: 12A rms. Two Loops, Outputs A and B: 10A RMS each. 24V BTL (equiv to 48V single-ended). Measured at 1.3 Ω , 1kHz standard continuous output for 8 hours.
Headphone Output	1/4" Headphone Jack, on front panel.
Required Loop Resistance	0.5 Ω to 1.5 Ω (DC) (stable). Amp will drive 5 Ω but output current is reduced.
AGC	Gain Range: +/- 25 dB. This is effectively 50 dB of dynamic at the highest setting. The Level setting allows the dynamic range to be variable. Minimum threshold: 40 dB lower than calibration level, capped at -80 dBFS (below this level, AGC is suspended) Target level: -9 dBFS RMS (-6 dBFS peak)
Metal Loss Compensation	Parametric EQ, Tilt Correction. Center frequency: adjustable 1 KHz - 9 KHz; Level: adjustable 0 dB to +12 dB. Maximum effective tilt correction applied = +3 dB at 1 kHz to 12 dB at 9 KHz.
Output Power (Speaker)	50 Watts X 1 Channel @ 4 Ω (35 Watts @ 8 Ω). Class D.
Loop Frequency Response	100Hz to 10kHz @400mA (Output A or B). Note this may be affected by several factors.
Speaker Frequency Response	20Hz - 20kHz (Output A)
Speaker Dynamic Range	>90 dB; A-weighted, typical
Speaker THD+N	0.07%; 50 watts into 4 Ω @ 20-20kHz
Loop THD	<1% at nominal power output, 1kHz sine wave
Front Controls	Front LCD display menu access/adjustment via control dial.
Remote Control/Configuration	Ethernet, USB, RS-232. Application "PC Mixer App" supports all 3 protocols.
Ethernet, Dante	Standard RJ-45 jack.
RS-232	Standard DB-9 COM port connector.
USB	Standard-B jack. USB 1.1, 2.0 or 3.0 supported.
Warranty	2 year limited
Approvals	CE, IC, UL, ULC, FCC, Industry Canada, RoHS, WEEE, CE, UL, CB scheme, cü

Digi-Loop DSP Dual Channel Loop Amplifiers

PLA DL 210 NET D Dante Specifications:

Channels	2 (either channel can be off, mixed, or summed to the loop output)
Minimum Latency	2 ms (set in Dante Controller, stored in Dante card)
Network Speed	100 Mbps
Audio Sample Rates	44.1 KHz, 48 KHz
Resolution	24 bits

NOTE: SPECIFICATIONS SUBJECT TO CHANGE WITHOUT NOTICE.

Architectural / Engineering Specifications

The loop amplifier shall be designed for rooms of up to 6500 sq. ft. (600 sq. m) with loop signals and is the ideal solution for events and meeting venues.

It shall have one XLR digital audio input for use with digital audio sources such as pro audio consoles with digital AES/EBU output, etc. It shall have an ethernet jack for Dante digital audio input.

It shall have an ethernet jack to provide configuration capability over an ethernet (10 base T) network. It shall have an additional ethernet jack for connection to a Dante network.

It shall have an RS-232 jack to provide control capability from 3rd-party controllers such as Crestron, AMX, Extron, etc.

It shall have a USB jack to provide access to internal configuration with a computer.

It shall have two MIC/LINE LEVEL inputs that can be configured as LINE (balanced) or as MICROPHONE input(s). These inputs shall be mixed with the RCA LINE inputs into one mono output for the loop.

It shall have two RCA LINE inputs that can be used to supply one or two channels of audio. These two channels shall be mixed together, then mixed with the two MIC/LINE inputs into one mono output for the loop.

It shall have a 70-100V input to provide a speaker-level input connection for use with distributed speaker systems.

It shall have two LINE OUTPUTS to provide loop-through connections for line level signals going to other equipment such as recording devices. These line outputs shall be the summed combination of the MIC/LINE LEVEL inputs and the RCA LINE inputs.

It shall have two LOOP OUTPUTS for running either one large loop, two individual loops, a phased-array system, or 1 loop + 1 speaker. Output A will be configurable in the menu to be a speaker output.

It shall have a 1/4" Headphone jack for monitoring.

It shall provide an output of up to 12A rms on output A, for one loop with optimum loop field strength. When both outputs A and B are used, each output will supply up to 10A rms.

It shall be compatible with either US or international power systems with the appropriate power cord.

The loop amplifier with the ethernet jack shall be the Williams Sound model PLA DL210NET.

The loop amplifier with the ethernet jack and Dante jack shall be the Williams Sound model PLA DL210NET-D.

Domestic Sales

Williams Sound, LLC
10300 Valley View Rd
Eden Prairie, MN 55344
Ph: 800-328-6190 / 952-943-2252
FAX: 952-943-2174
Email: info@williamssound.com
Web: www.williamssound.com

International Sales

International Sales Department
Williams Sound, LLC
10300 Valley View Rd
Eden Prairie, MN 55344 USA
Phone: +1 952 943 2252
Fax: +1 952 943 2174
Email: info-intl@williamssound.com
Web: www.williamssound.com



800.843.3544 / info@williamssound.com / www.williamssound.com